

# KP-2 / KP-4 / KP-8

## 2/4/8 Button In-Wall PoE Keypad Controller

### Reference Guide



KP-2 / KP-4 / KP-8 with Decora® style wall plate  
(not included)



KP-2 / KP-4 / KP-8  
(as sold without Decora® style wall plate)

Available with two, four, or eight fully programmable buttons, the KP keypad provides intuitive two-way feedback via configurable backlight colors for each button.

KP keypads ship with two sets of keypad frames and matching keycaps - one white and one black. For an elevated look and control experience, use RTI's Laser Shark™ engraving service to personalize the keycaps with custom text and graphics. These are available in White and Satin Black.

Compatible with Decora® style wall plates and sized to fit in a single gang US box, the KP keypads seamlessly integrate into homes and commercial buildings with a clean, intuitive on-wall control solution to match any decor.

## Key Features

- Two, four or eight assignable/programmable buttons.
- FREE Laser Engraving for custom text and graphics. Use device's serial number for order code in the Laser Shark Software.
- Control communication and power over Ethernet (PoE).
- Ships with white keypad frame and keycap set, and a black keypad frame and keypad set.
- Backlight color is programmable on each button (16 colors available).
- Completely customizable and programmable.
- Fits in a single gang electrical outlet box.
- Network or USB Programming.
- Use any standard Decora® type wallplate (not included).

## Product Contents

- KP-2, KP-4 or KP-8 In-Wall Keypad Controller
- Black and White Keypad Frames (2)
- Black and White Keycap Sets (2)
- Free Laser Shark engraving for one keycap set (1)
- Screws (2)

## Overview

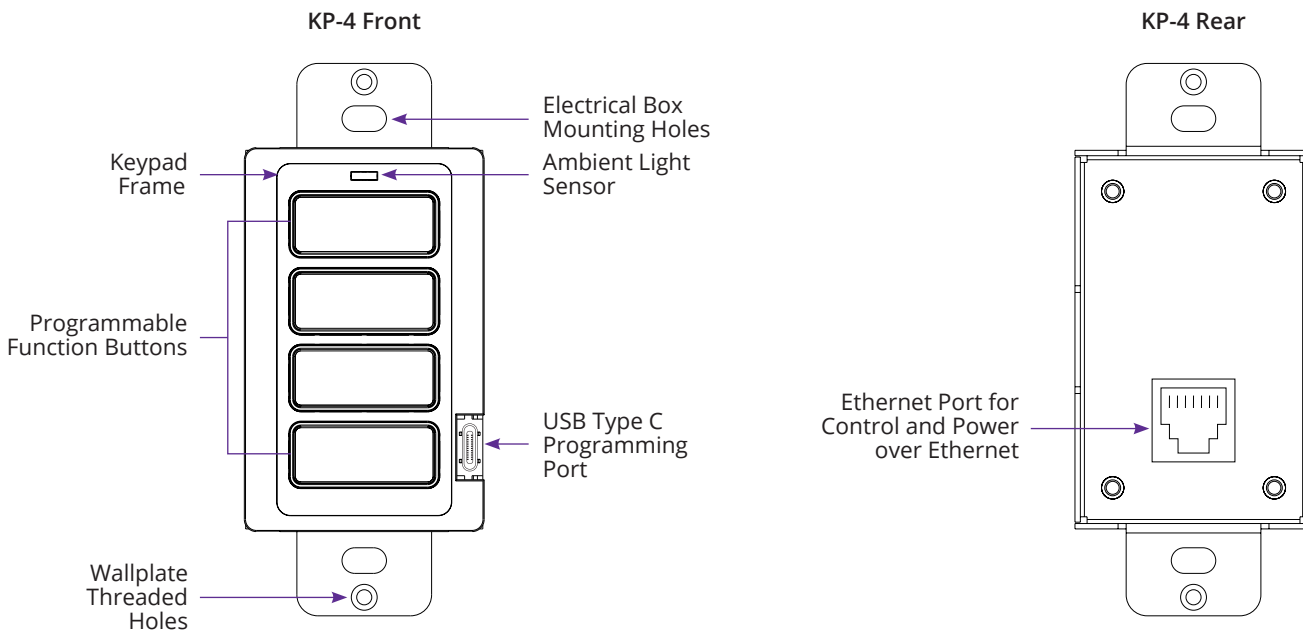

## Mounting

The KP keypad is designed for flush-mount installations in walls or cabinets. It requires an available mounting depth of 2.0 inches (50mm) from the front surface of the wall. Normally, the KP keypad is mounted in a standard single-gang electrical box or mud-ring.

## Powering the KP Keypad

Apply power via the POE port: Connect the KP unit to a PoE network switch using Cat-5/6 cable from the KP Ethernet Port to the network switch (see diagram on page 4). The network router will assign an IP address to the KP keypad automatically and allow it to join the network.

- The KP Keypad is set to use DHCP by default.
- Network router must have DHCP enabled.

Once the KP is connected to PoE, the LED's will first flash red and white during boot, then flash red until it is assigned properly on the LAN. Solid red LED's after this process indicate that there was an issue communicating on the LAN.

The KP keypad will enter an idle mode after a programmed time of inactivity. After entering idle mode, the KP keypad is activated by touching any button.

## Programming

### The KP Keypad Interface

The KP keypad is a flexible, programmable interface. In the most basic configuration, the KP keypad buttons can each be used to execute a single function or “scene”. If more functionality is required, the buttons can execute complex macros, jump to other “pages”, and change backlight colors to provide status feedback. This level of customization allows almost any type of user interface functionality to be created.

### Updating Firmware

It is highly recommended that this and all RTI products have the latest firmware installed. The firmware can be found in the Dealer section of the RTI website ([www.rticontrol.com](http://www.rticontrol.com)). The firmware can be updated by Ethernet or USB Type C using the latest version of Integration Designer.

### Updating Software

RTI’s Integration Designer data files can be downloaded to the KP keypad using a USB Type C cable or over the network via Ethernet.

## Swapping the Keypad Frame and Keycap (Black/White)

The KP keypad ships with a black and a white keypad frame and matching keycaps.

The procedure for swapping the keypad frame and keycaps is:

1. Use a small screwdriver to release the tabs (shown) and pry off the keypad frame.
2. Attach the keypad frame with the desired color and the matching keycap to the KP enclosure.

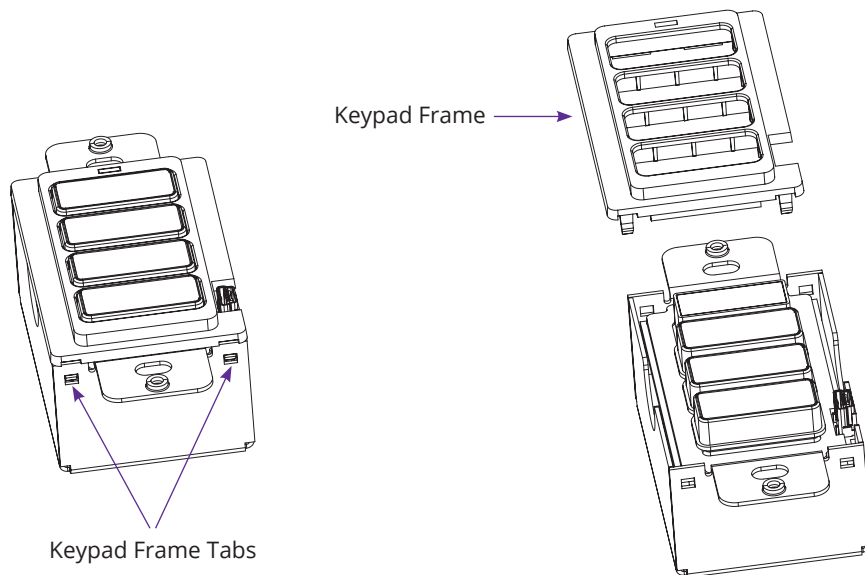

## Button Labels

The KP keypad includes a set of labels for attaching to the face of each button. The label sheets include a wide variety of function names that are appropriate for most common scenarios. The KP keypad Kit supports the use of custom engraved Laser Shark button keycaps (find details on the [rticontrol.com](http://rticontrol.com) dealer section).

The procedure for attaching labels and keycaps is:

1. Use a small screwdriver to release the tabs (shown) and pry off the keypad frame.
2. Remove the clear keycap.

Using Button Labels (included)

3. Center the selected button label within the rubber pocket.
4. Replace the clear keycap.
5. Repeat the steps above for each button, and then reattach the keypad frame.

Using Laser Shark Keycaps

3. Place the selected Laser Shark keycap over the button and press down. (The clear keycap may be discarded).
4. Repeat the steps above for each button, and then reattach the keypad frame.

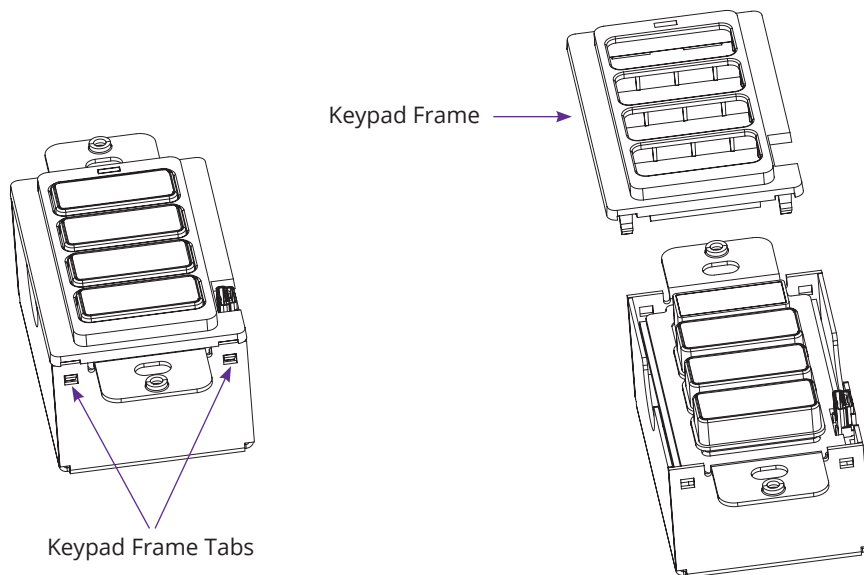

## Connections

### Control/Power Port

The Ethernet Port on the KP keypad uses a Cat-5/6 cable with RJ-45 termination. When used in conjunction with an RTI control processor (e.g. RTI XP-6s) and an PoE Ethernet Switch, this port serves as the power source for the KP keypad as well as the as the control port (see diagram for connecting).

### USB Port

The KP Keypad USB port (located on the front of the unit beneath the bezel) is used to update firmware and to program the date file using a Type C USB cable.

## KP Keypad Wiring

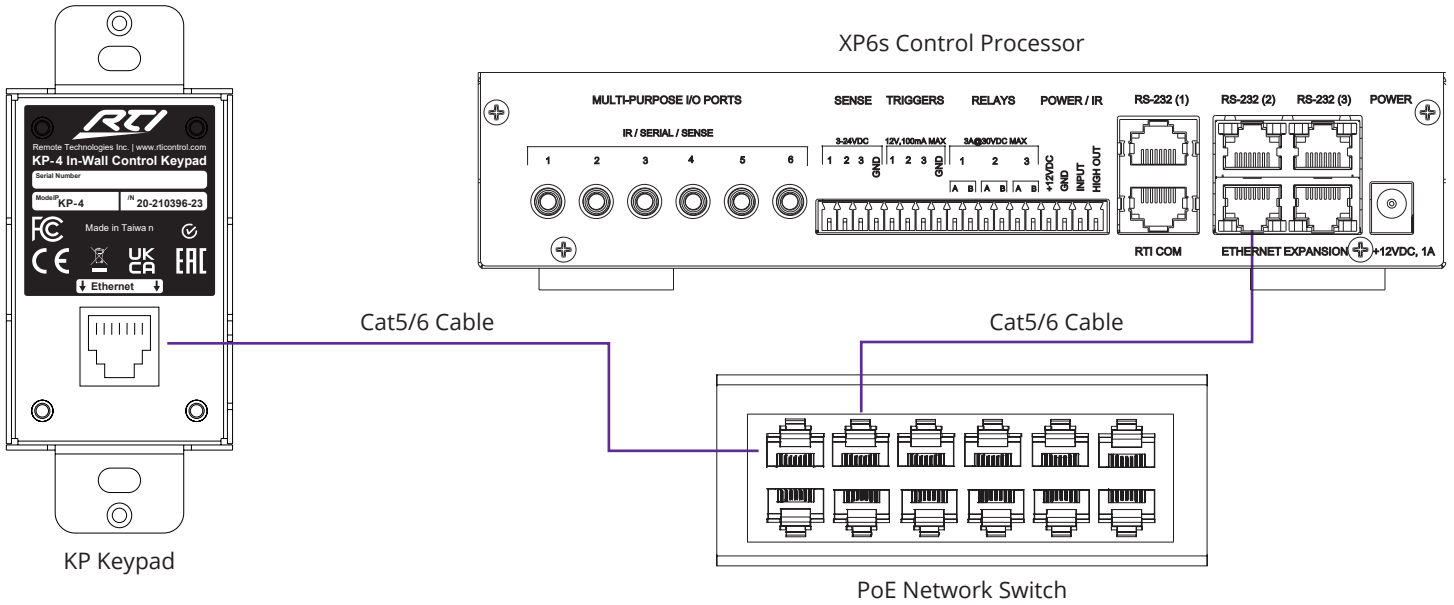

## Dimensions

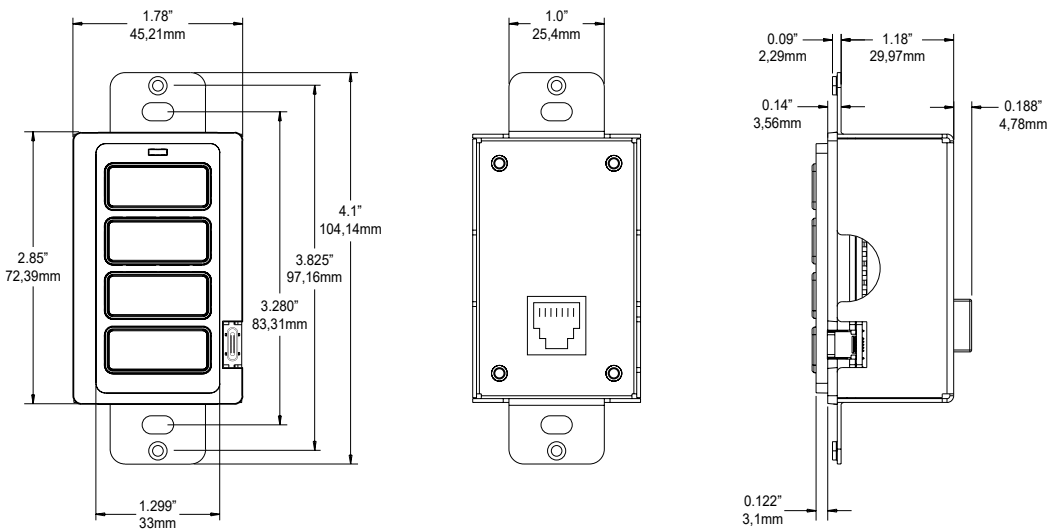

## Safety Suggestions

### **Read and Follow Instructions**

Read all safety and operating instructions before operating the unit.

### **Retain Instructions**

Keep the safety and operating instructions for future reference.

### **Heed Warnings**

Adhere to all warnings on the unit and in the operating instructions.

### **Accessories**

Only use attachments/accessories specified by the manufacturer.

### **Heat**

Keep the unit away from heat sources such as radiators, heat registers, stoves, etc., including amplifiers that produce heat.

### **Power**

Unplug this apparatus during lightning storms or when unused for long periods of time.

### **Power Sources**

Connect the unit only to a power source of the type described in the operating instructions, or as marked on the unit.

### **Power Sources**

Connect the unit only to a power supply of the type described in the operating instructions, or as marked on the unit.

### **Power Cord Protection**

Route power supply cords so that they are not likely to be walked on or pinched by items placed on or against them, paying particular attention to the cord plugs at power receptacles and at the point at which they exit from the unit.

### **Water and Moisture**

Do not use the unit near water—for example, near a sink, in a wet basement, near a swimming pool, near an open window, etc.

### **Object and Liquid Entry**

Do not allow objects to fall or liquids to be spilled into the enclosure through openings.

### **Servicing**

Do not attempt any service beyond that described in the operating instructions. Refer all other service needs to qualified service personnel.

### Damage Requiring Service

The unit should be serviced by qualified service personnel when:

- The power supply cord or the plug has been damaged.
- Objects have fallen or liquid has been spilled into the unit.
- The unit has been exposed to rain.
- The unit does not appear to operate normally or exhibits a marked change in performance.
- The unit has been dropped or the enclosure has been damaged.

## Cleaning

To clean this product, lightly dampen a lint-free cloth with plain water or a mild detergent and wipe the outer surfaces. **NOTE:** Do not use harsh chemicals as damage to the unit may occur.

## Federal Communications Commission Notice

This equipment has been tested and found to comply with the limits for a Class B digital device, pursuant to Part 15 of the FCC Rules. These limits are designed to provide reasonable protection against harmful interference in a residential installation. Any changes or modifications not expressly approved by the party responsible for compliance could void the user's authority to operate the device.

This equipment generates, uses, and can radiate radio frequency energy and, if not installed and used in accordance with the instructions, may cause harmful interference to radio communications. However, there is no guarantee that interference will not occur in a particular installation.

If this equipment does cause harmful interference to radio or television reception, which can be determined by turning the equipment off and on, the user is encouraged to try to correct the interference by one or more of the following measures:

- Reorient or relocate the receiving antenna.
- Increase the separation between the equipment and the receiver.
- Connect the equipment into an outlet on a circuit different from that to which the receiver is connected.
- Consult the dealer or an experienced radio/TV technician for help.

This device complies with Part 15 of the FCC Rules. Operation is subject to the following two conditions:

1. This device may not cause harmful interference.
2. This device must accept any interference received including interference that may cause undesired operation.

## Industry Canada Compliance Statement

This device complies with Industry Canada license-exempt RSS standard(s). Operation is subject to the following two conditions:

1. This device may not cause harmful interference.
2. This device must accept any interference received including interference that may cause undesired operation.

Cet appareil est conforme avec Industrie Canada exempts de licence standard RSS (s). Son fonctionnement est soumis aux deux conditions suivantes:

1. Ce dispositif ne peut causer des interférences nuisibles.
2. Cet appareil doit accepter toute interférence reçue y compris des interférences qui peuvent provoquer un fonctionnement indésirable.



## Declaration of Conformity (DoC)

The Declaration of Conformity for this product can be found on the RTI website at:  
[www.rticontrol.com/declaration-of-conformity](http://www.rticontrol.com/declaration-of-conformity)

## Contacting RTI

For news about the latest updates, new product information, and new accessories, please visit our web site at: [www.rticontrol.com](http://www.rticontrol.com)

For general information, you can contact RTI at:

Remote Technologies Incorporated  
5775 12th Ave. E Suite 180  
Shakopee, MN 55379  
Tel. +1 (952) 253-3100  
[info@rticontrol.com](mailto:info@rticontrol.com)

## Service & Support

If you are encountering any problems or have a question about your RTI product, please contact RTI Technical Support for assistance (see the Contacting RTI section of this guide for contact details).

RTI provides technical support by telephone or e-mail. For the highest quality service, please have the following information ready:

- Your Name
- Company Name
- Telephone Number
- E-mail Address
- Product model and serial number (if applicable)

If you are having a problem with hardware, please note the equipment in your system, a description of the problem, and any troubleshooting you have already tried.

**\*Please do not return products to RTI without return authorization.\***

## Limited Warranty

RTI warrants new products for a period of three (3) years (excluding consumables such as rechargeable batteries which are warranted for one (1) year) from the date of purchase by the original purchaser (end user) directly from RTI / Pro Control (herein referred to as "RTI"), or an authorized RTI dealer.

Warranty claims may be initiated by an authorized RTI dealer using the original dated sales receipt or other proof of warranty coverage. In the absence of the receipt of purchase from the original dealer, RTI will provide warranty coverage extension of six (6) months from the date code of the product. Note: RTI warranty is limited to the provisions set forth in this policy and does not preclude any other warranties offered by third parties who are solely responsible for those other warranties.

Except as specified below, this warranty covers defects in product material and workmanship. The following are not covered by the warranty:

- Product purchased via unauthorized sellers or internet sites will not be serviced- regardless of purchase date.
- Damages caused by accident, misuse, abuse, neglect or acts of God.
- Cosmetic damage, including, but not limited to, scratches, dents and normal wear and tear.
- Failure to follow instructions contained in the Product Installation Guide.
- Damages due to products used in an application or environment other than that for which it was intended, improper installation procedures or adverse environmental factors such as incorrect line voltages, improper wiring, or insufficient ventilation.

- Repair or attempted repair by anyone other than RTI and Pro Control or authorized service partners.
- Failure to perform recommended periodic maintenance.
- Causes other than product defects, including lack of skill, competence or experience of user.
- Damage due to shipment of this product (claims must be made to the carrier).
- Altered unit or altered serial number: defaced, modified or removed.

RTI Control is also not liable for:

- Damages caused by its products or for failure of its products to perform, including any labor costs, lost profits, lost savings, incidental damages, or consequential damages.
- Damages based upon inconvenience, loss of use of the product, loss of time, interrupted operation, commercial loss, any claim made by a third party or made on behalf of a third party.
- Loss of, or damage to, data, computer systems or computer programs.

RTI's liability for any defective product is limited to repair or replacement of the product, at the sole discretion of RTI. In cases where the warranty policy conflicts with local laws, the local laws will be adopted.

## Disclaimer

All rights are reserved. No part of this document may be photocopied, reproduced, or translated without the prior written notice of Remote Technologies Incorporated.

The information contained in this document is subject to change without notice. Remote Technologies Incorporated shall not be liable for errors or omissions contained herein or for consequential damages in connection with the furnishing, performance, or use of this guide.

Integration Designer, and the RTI logo are registered trademarks of Remote Technologies Incorporated.

Other brands and their products are trademarks or registered trademarks of their respective holders.



Remote Technologies Incorporated  
5775 12th Avenue East, Suite 180  
Shakopee, MN 55379  
Tel: 952-253-3100  
[www.rticontrol.com](http://www.rticontrol.com)